

# Insulated Fiberglass Roofing Conveyor



**FBR-6-SERIES**

Patent #5,984,077



**The Leader  
In Rooftop  
Delivery!**

**LEASBY**  
Manufacturing Company Inc. of Utah

# Cleasby Fiberglass Conveyors

Advanced FBR Series insulated fiberglass roofing conveyors are designed to greatly reduce the risks of accidental electrocution in the event the conveyor touches a power line. The conveyor frame is built out of fiberglass. It has non-conductive hydraulic lines and a non-conductive belt. It is very important that if any repairs or replacements are made that the same non-conductive fiberglass, hydraulic lines and belt are used that the manufacture uses.

*Patent #5,984,077*

## FBR CONVEYOR BENEFITS

### 1. ALL FIBERGLASS FRAME:

This greatly reduces the risk of accidental electrocutions.

### 2. LIGHTER IN WEIGHT:

This reduces the stress and pressure on the turntable which in turn gives longer life to the equipment.

### 3. STRUCTURALLY STRONG AND DURABLE:

This conveyor is more flexible and forgiving than metal conveyors. It will "spring back" upon impact in most cases rather than bend or dent.

### 4. NO WELDING REQUIRED FOR ASSEMBLY OR REPAIR:

This conveyor is assembled using different types of fasteners which make repairs easier and less expensive.

### 5. NO RUST OR METAL FATIGUE:

Fiberglass doesn't rust. This greatly reduces the cost and time involved to repair metal fatigue or rust.

## FBR CONVEYOR FEATURES

- Stop and start control at top of conveyor.
- 16" wide belt with 4" high replaceable cleats.
- Special belt tracking guide.
- Standard conveyor lengths: 26', 31', 36', 38', 41'.

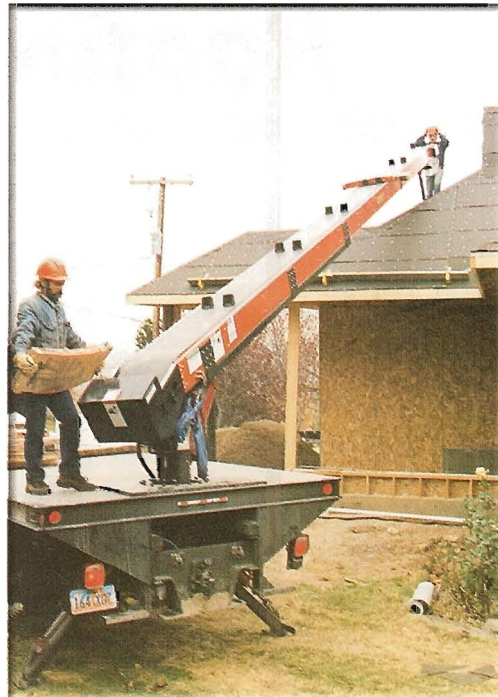

## CONVEYOR WEIGHTS: (Approximate)

FBR-6-26	840 lbs.	FBR-6-38	1225 lbs.
FBR-6-31	1000 lbs.	FBR-6-41	1325lbs.
FBR-6-36	1160 lbs.		

# Cleasby Hydraulic Turntables

## ROTATION HYDRAULIC GEAR TURNTABLES

All turntables have four hydraulic functions and are permanently mounted on truck.

### MODEL

### TURNTABLE HYDRAULIC FUNCTIONS

#### RTH-3000

Weight  
1325lbs

- 1) Post lifts up to 5' for load clearance, lowers down to 30" for conveyor loading.
- 2) Conveyor elevates to 70 degrees.
- 3) Forward and reverse drive for belt or chain.
- 4) 360 degrees continuous hydraulic rotation.

#### RTH-4000

Weight  
1400lbs

- 1) Post lifts up to 6' for load clearance, lowers down to 30" for conveyor loading.
- 2) Conveyor elevates to 70 degrees.
- 3) Forward and reverse drive for belt or chain.
- 4) 360 degree continuous hydraulic rotation.

#### RTH-6000

Weight  
1500lbs

- 1) Post lifts up to 7.5' for load clearance, lowers down to 30" for conveyor loading.
- 2) Conveyor elevates to 70 degrees.
- 3) Forward and reverse drive for belt or chain.
- 4) 360 degree continuous hydraulic rotation.

**\*\*The turntables listed above are standard models used with conveyors 36' long or shorter. For conveyors ordered longer than 36' (38', 41') you must use the Heavy Duty RTH Turntables. (See Heavy Duty Turntable Price List).**

## Removable Hydraulic Turntables

All hydraulic removable turntables are rotated by hand.

### MODEL

### TURNTABLE HYDRAULIC FUNCTIONS

#### G7LU-18

Weight  
850 lbs

- 1) Post lifts and lowers. Lifts up to 4½' for load clearance, lowers to 3' for conveyor loading.
- 2) Boom elevates to 70 degrees.
- 3) Forward and reverse drive for belt.

#### G5AU

Weight  
750 lbs

- 1) Boom elevates to 70 degrees.
- 2) Forward and reverse drive for belt.

**Removable turntables allow you to use your truck for other purposes.  
It only takes seconds to remove, leaving only the base plate.**



**ON THE TRUCK**



**OFF THE TRUCK**

# Truck and Conveyor Specifications

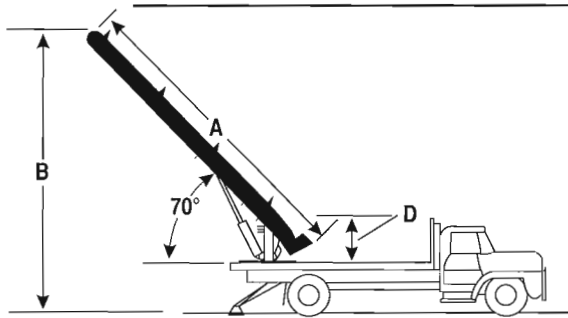

**FBR-6 Conveyor**

	TRUCKBED LENGTH						
	18'	20'	22'	24'	26'	26'	28'
<b>A</b> Conveyor Length	26'	31'	31'	36'	36'	38'	41'
<b>B</b> Max. Discharge	26'	31'	31'	36'	36'	38'	41'
<b>C</b> Cab to Axle*							
Minimum	120"	138"	150"	168"	174"	174"***	181"***
Recommended	138"	138"	156"	168"	174"	174"***	181"***
Maximum	144"	156"	168"	174"	186"	186"***	198"***

\*For single axle trucks, Cab to trunion is 8" longer. \*\*Cab to trunion measurement.

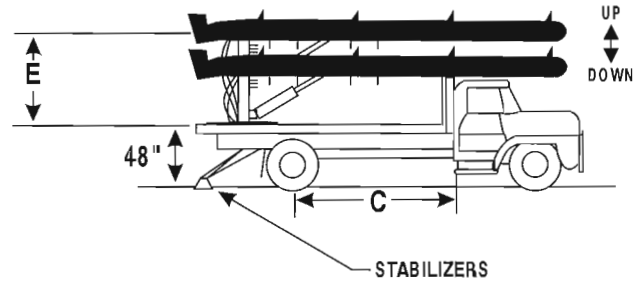

**RTH-Turntable**

	Turntables		
	RTH-3000	RTH-4000	RTH-6000
<b>D</b> Min. Loading Height	30"	30"	30"
<b>E</b> Max. Bed Clearance	60"	72"	90"
Rotation	360° Hydraulic	360° Hydraulic	360° Hydraulic

Note: Heavy duty turntables required for conveyors over 36' long.

## TURNTABLE INSTALLATION

The hydraulic turntable is easily installed by cutting a hole in the bed for the post, putting base plate on bed, installing eight case hardened bolts; two in each corner of plate and by tightening corner bolts which secures turntable to truck bed and truck frame. Pump and reservoir is included with turntable. See mounting instructions for more details.

### Quick and Easy

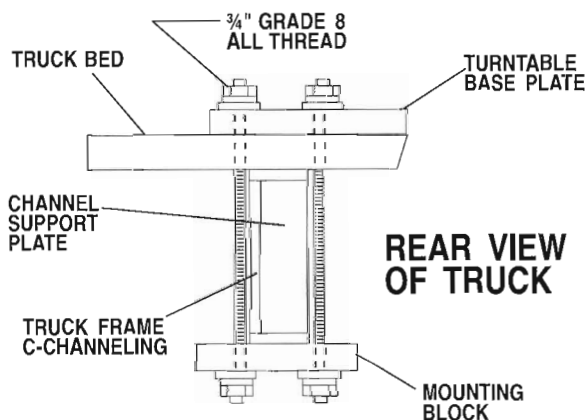

## HYDRAULIC STABILIZERS

Stabilizers are recommended for all trucks. They are available from the factory. They are required on all trucks with conveyors 36' and longer.



Weight: 350 lbs.

# GLEASBY

Manufacturing Company Inc. of Utah

362 South Main, Clearfield, Utah 84015  
801-773-1311 • 800-453-2446 • Fax 801-773-8608